

CAPACITY	SYMBOL/ SERIAL NO.	CIRCUIT DIAGRAM
AC220V~240V, 50/60Hz		
13W		

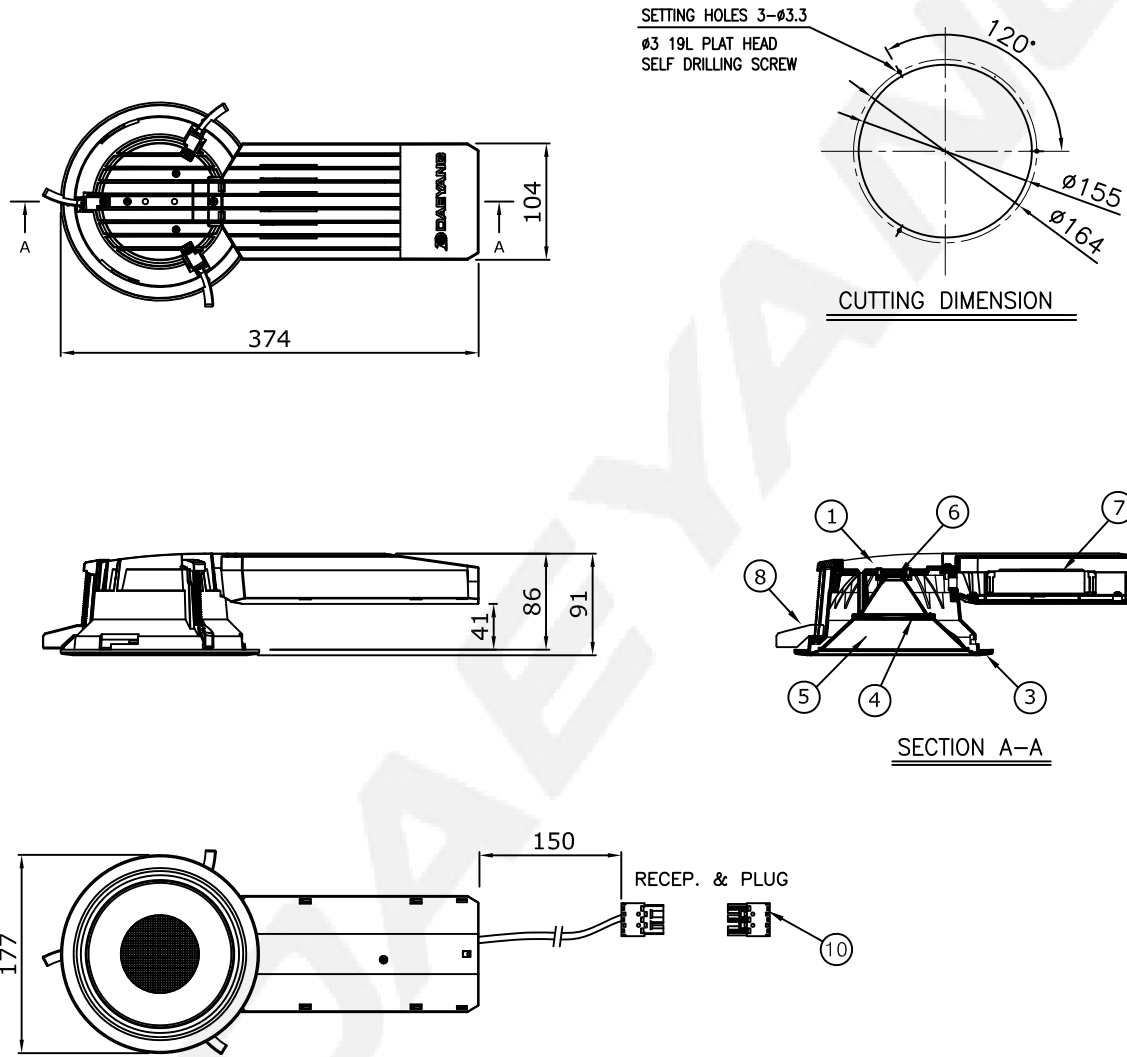

10	3P CONNECTOR	RECEP. & PLUG SET	1		5	REFLECTOR	POLYCARBONATE	1	
9	TERMINAL BLOCK	-	1	3P	4	DIFFUSER	POLYCARBONATE	1	MILKY
8	FITTING SUPPORT	POLYCARBONATE	3		3	FASCIA	POLYCARBONATE	1	WHITE
7	LED driver	-	1		2	BODY	POLYCARBONATE	1	
6	LED module	-	1	3,000 \pm 300K	1	FRONT HEAD	ALUMINIUM DIE CASTING	1	
NO.	NAME OF PARTS	MATERIAL	Q'TY	REMARKS	NO.	NAME OF PARTS	MATERIAL	Q'TY	REMARKS

APPROVED	J. W. PARK	UNIT	MM	TITLE LED DOWN LIGHT NORMAL(ON-OFF) TYPE FOR MARINE USE					
CHECKED	S. M. SON	SCALE	N/S						
DRAWING	B. K. HWANG	COLOR	N-9.3						
DATE	2023.06.30	IP	20						
				MODEL NO.	LEC0115NFL-P20613WPtC30-C3PW	WEIGHT	1.1 Kg		
				DWG NO.	L01710195	SHEET NO.	1		

NO	CONTENT	DATE	REVISER	APPROVAL
△				
△				
△				

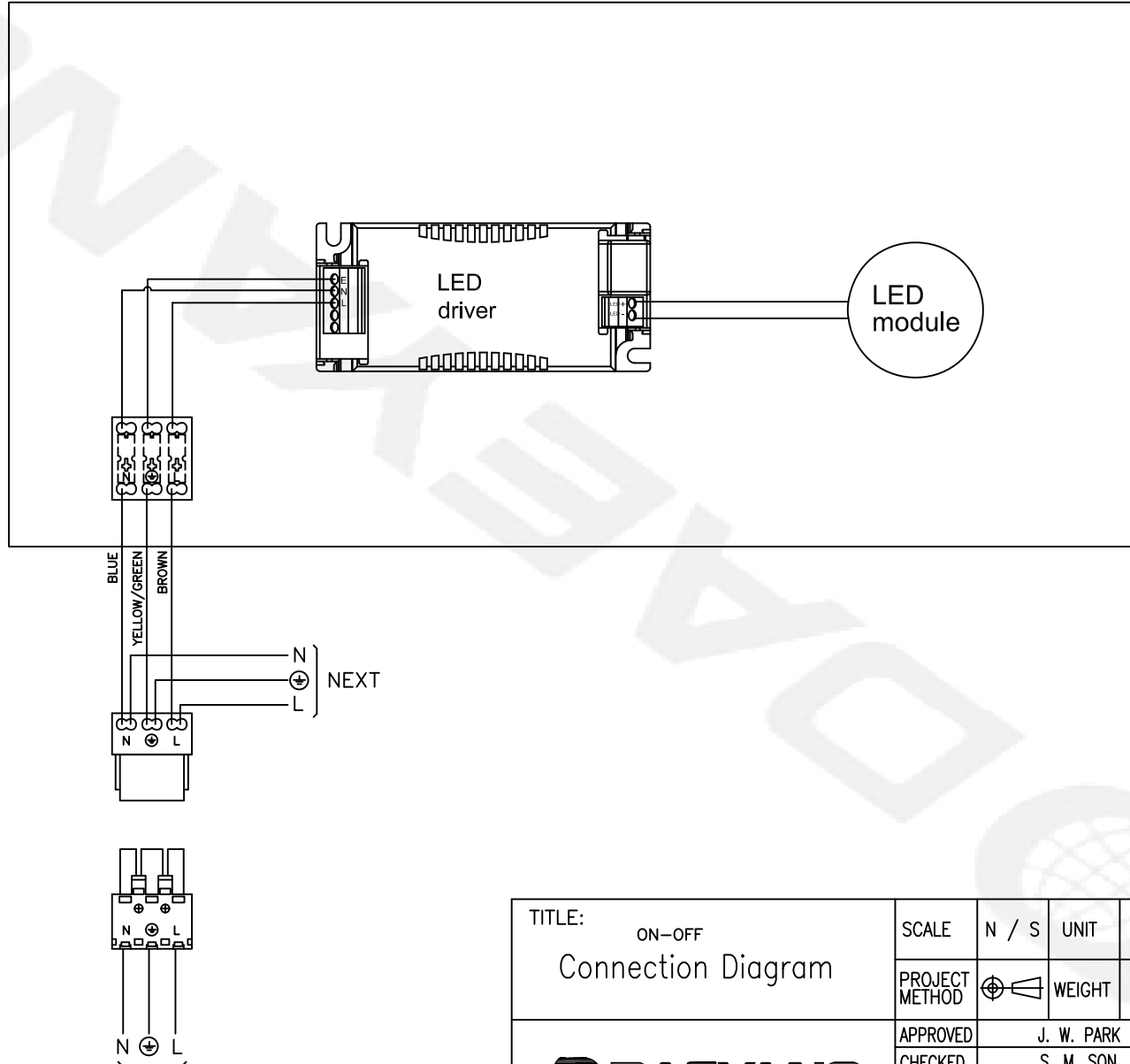

TITLE: ON-OFF Connection Diagram		SCALE	N / S	UNIT	MM	NO.	REVISED
		PROJECT METHOD	⊕	WEIGHT	KG	△	
		APPROVED	J. W. PARK			△	
		CHECKED	S. M. SON			△	
		DRAWN	B. K. HWANG			MATERIAL	ASS'Y
		DATE	2023. 03. 29			DWG NO.	
						SHEET NO.	1-A